

### 0603

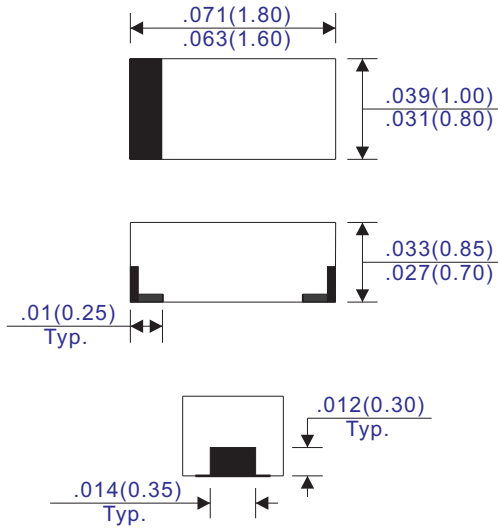

Unit :inch(mm)

### 1005

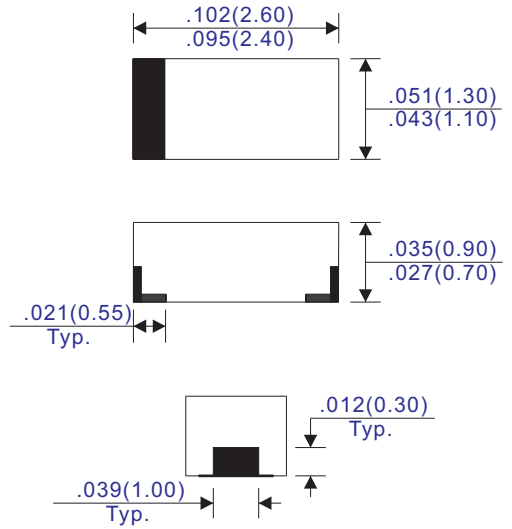

Unit :inch(mm)

### SOD-723

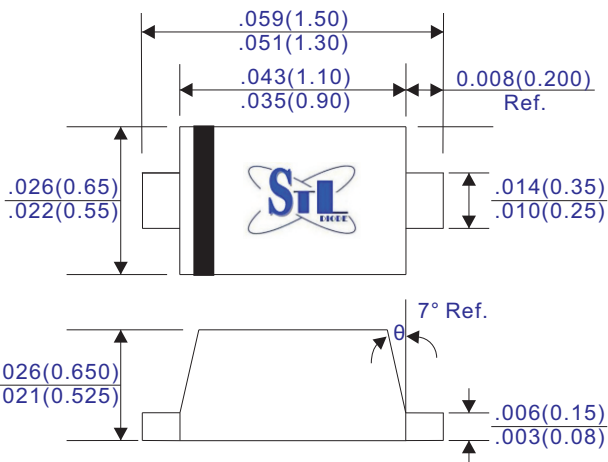

Unit :inch(mm)

### SOD-523

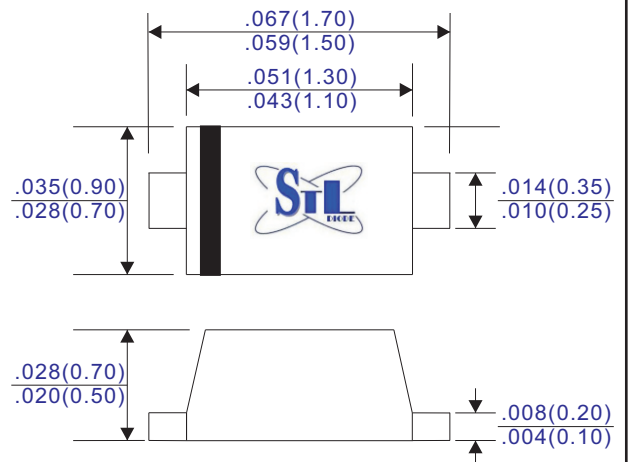

Unit :inch(mm)

### SOD-323

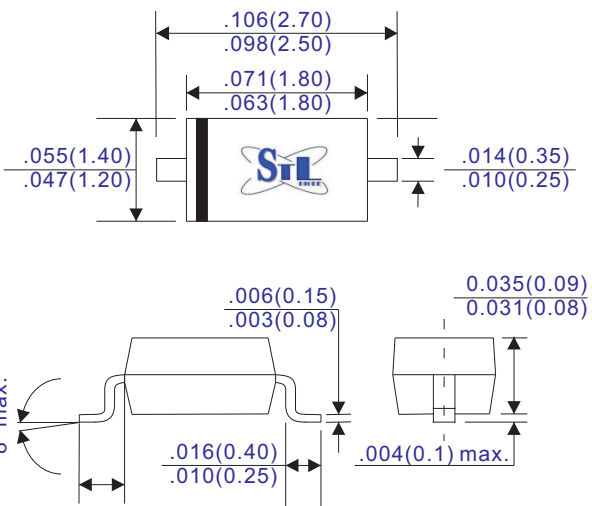

Unit :inch(mm)

### SOD-123

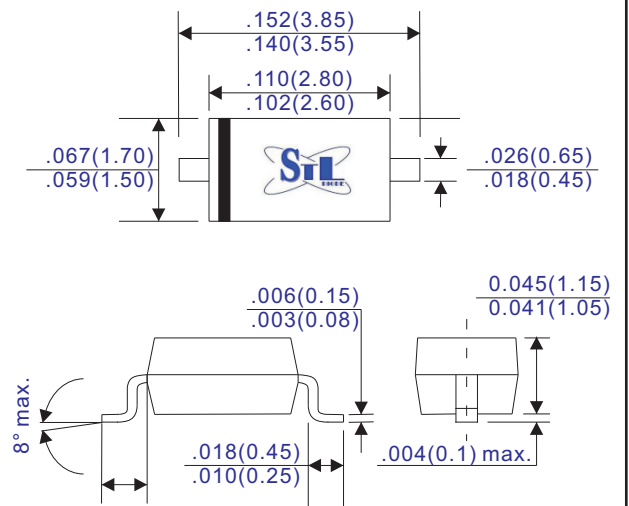

Unit :inch(mm)

## DO-213AA(Mini-Melf)

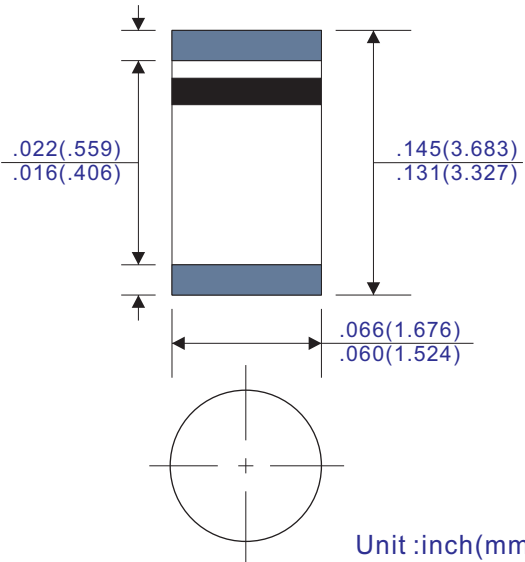

## SOD-80 (Glass Mini-Melf)

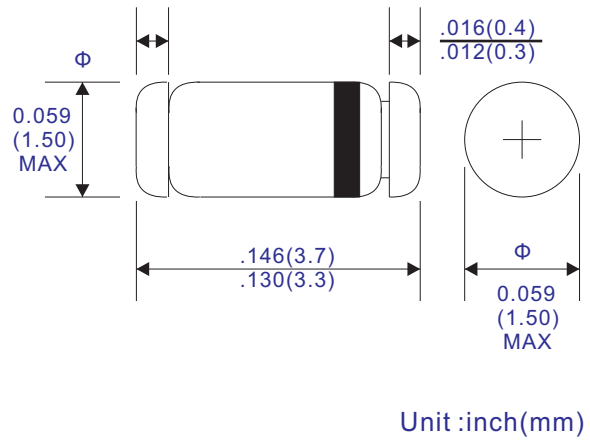

## SOT-523

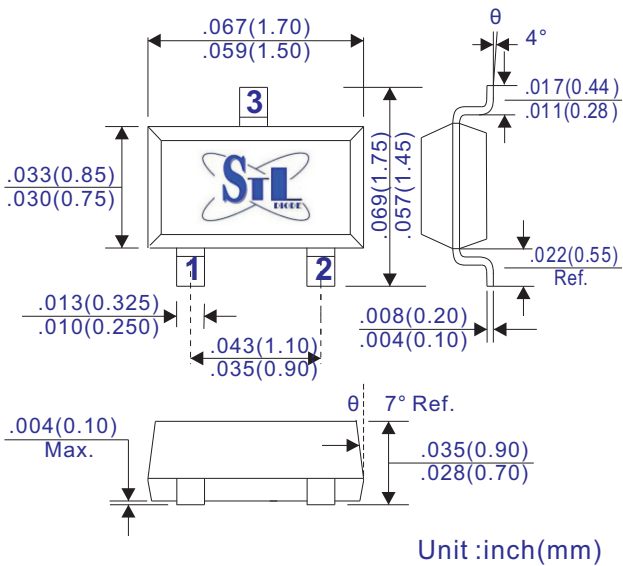

## SOT-563

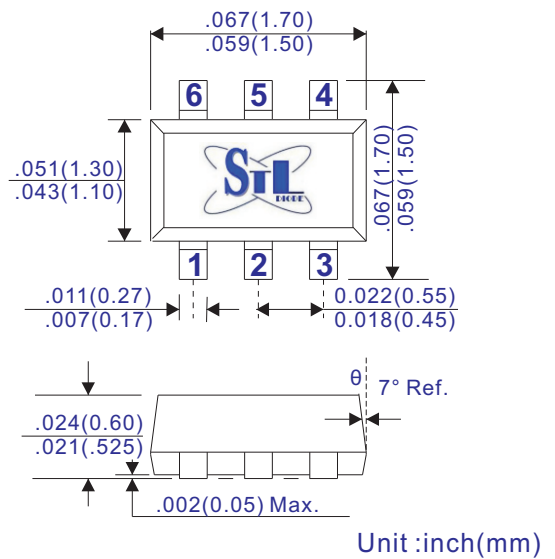

## SOT-553

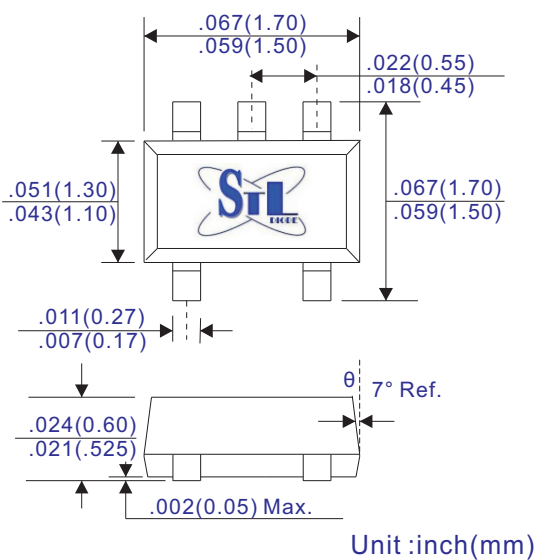

## SOT-323

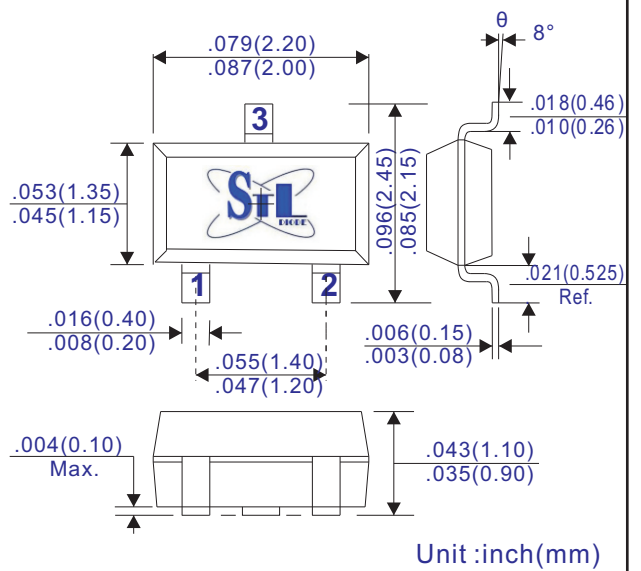

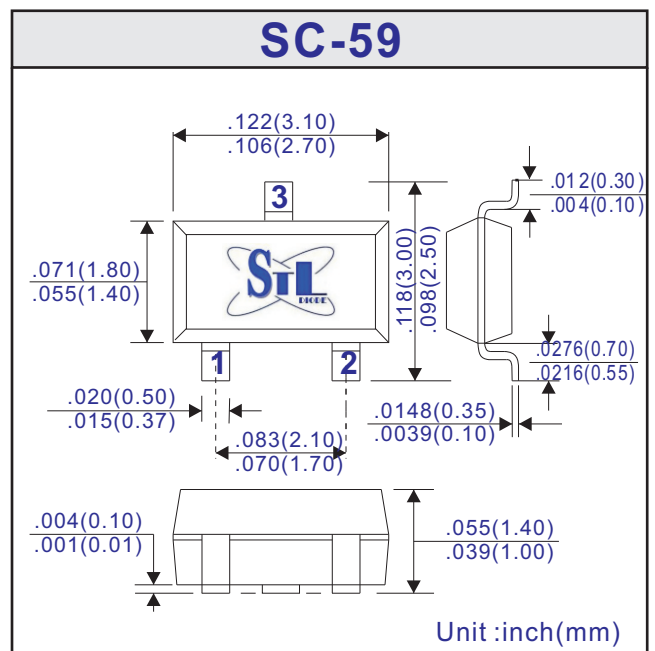
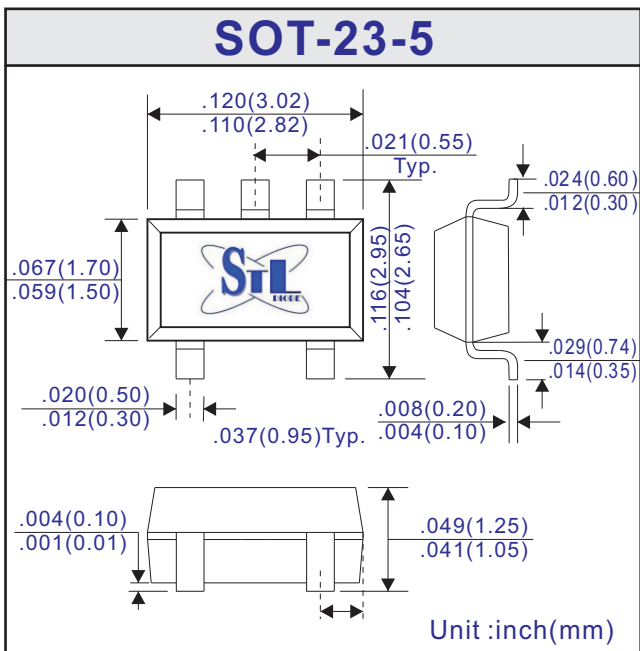
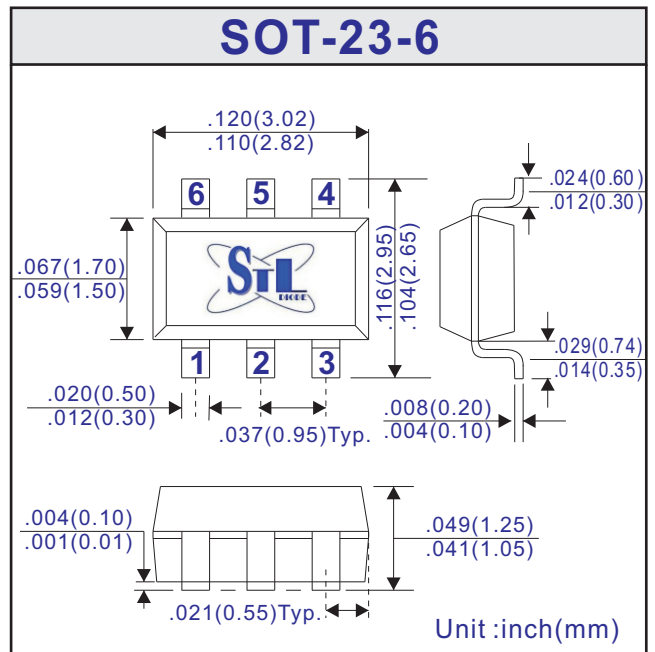
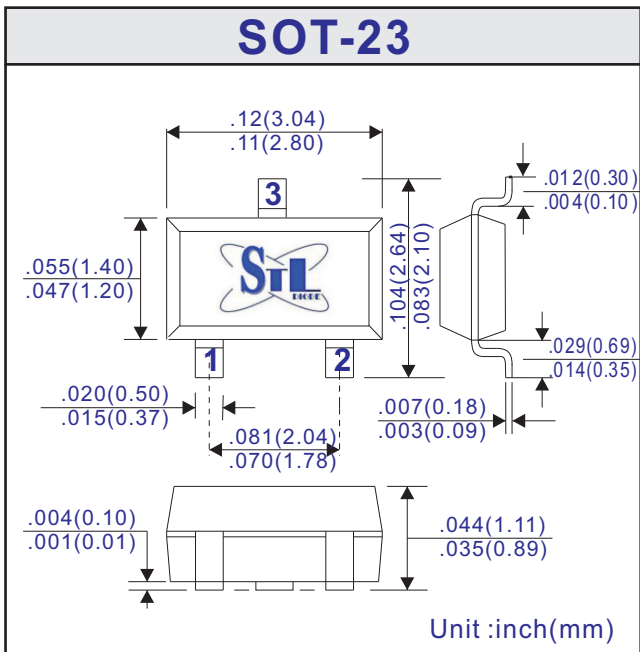
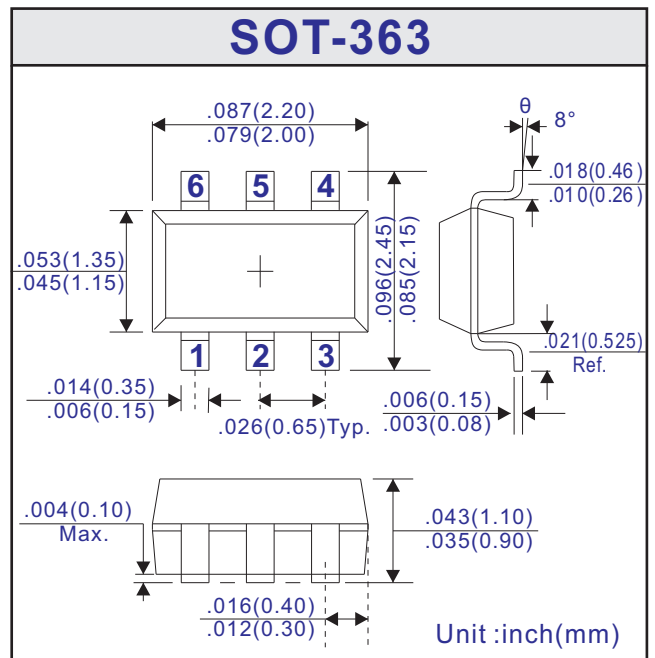
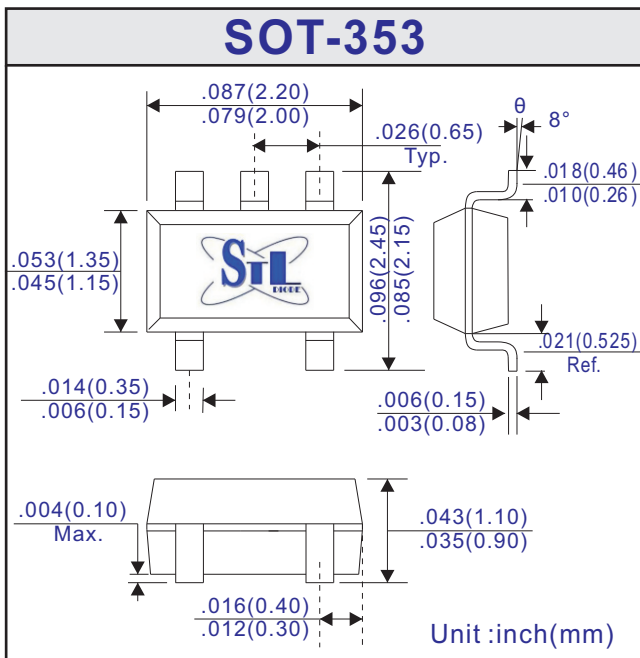

## DO-213AB(MELF)

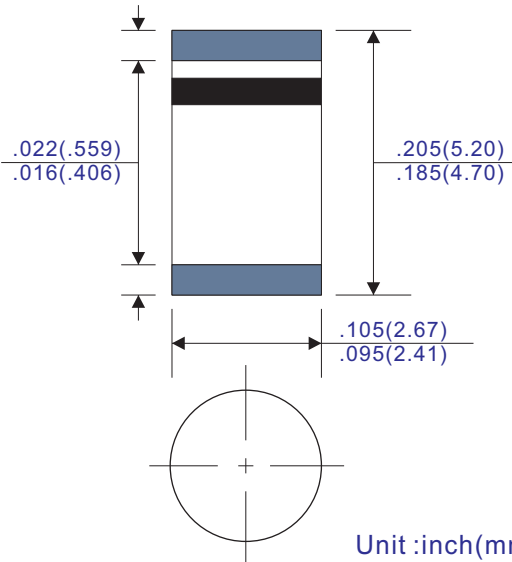

## LL-41 (Glass Melf)

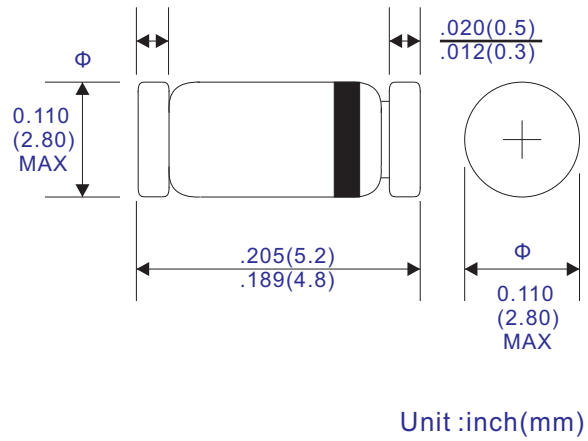

## Mini-SMA

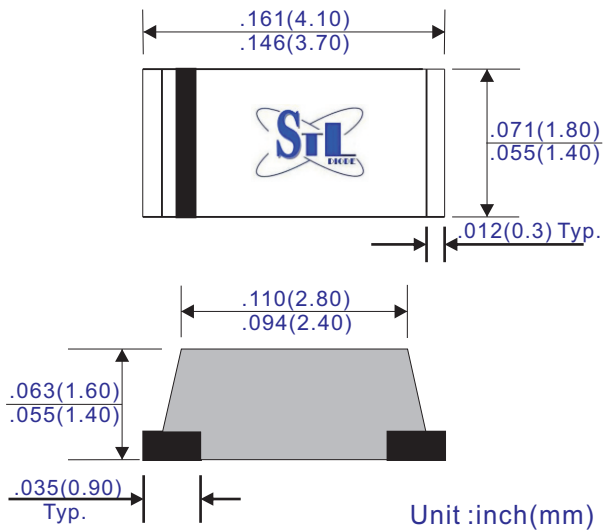

## SMA (DO-214AC)

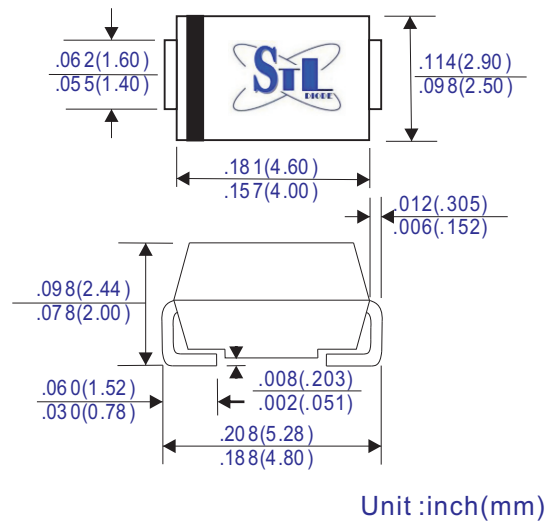

## SMB (DO-214AA)

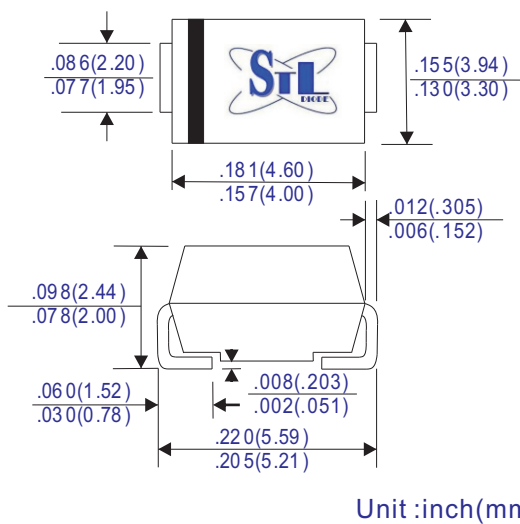

## SMC (DO-214AB)

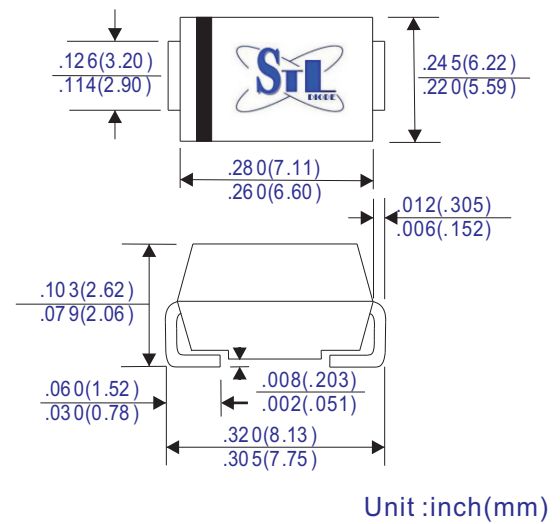

## SMD Mini-DIP (MDS)

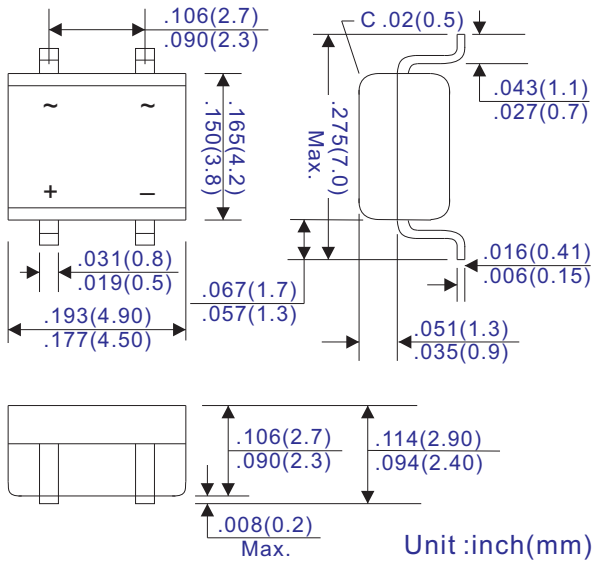

## SMD DIP Bridge(DFS)

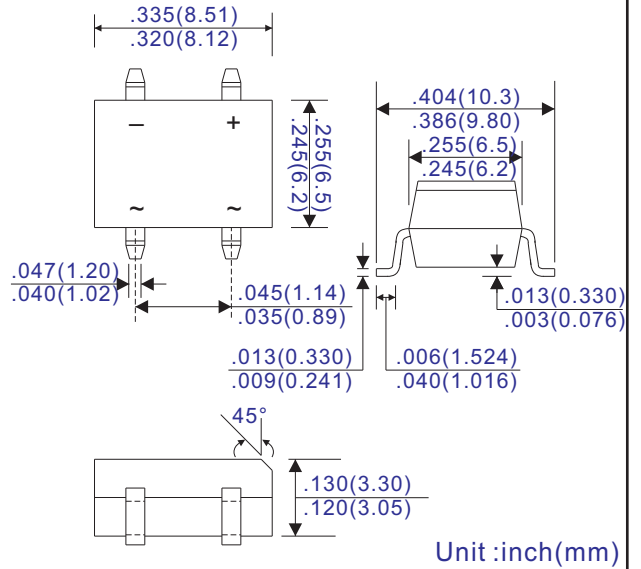

## TO-252 ( D-Pak)

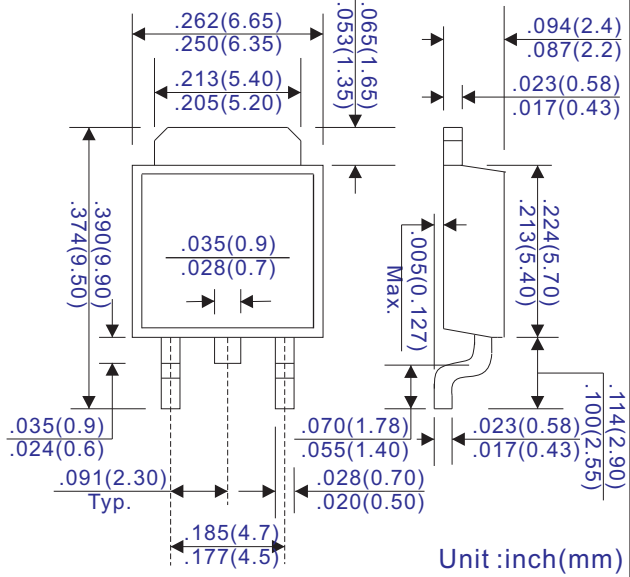

## TO-263-2L(D2-Pak)

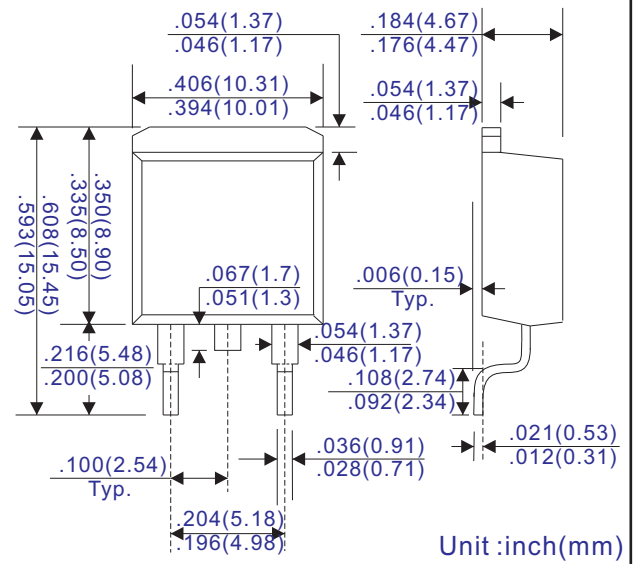

## SOT-89

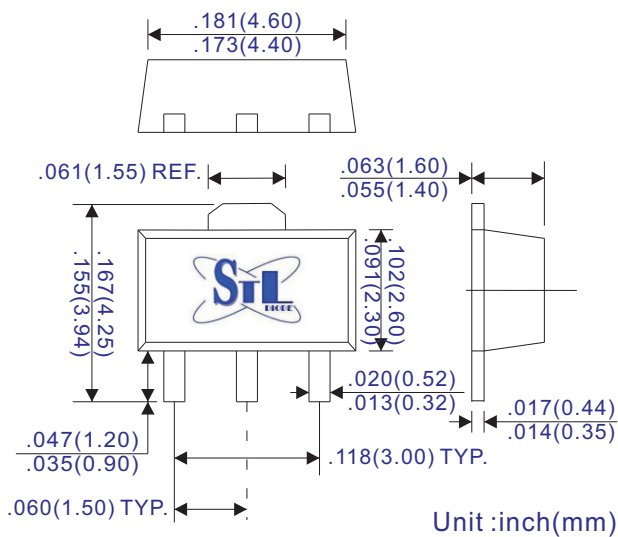

## HSMA (DO-214AC)

